

The XCaliber Hybrid Fixator

By Dr. S. Berki, Dr. V. Caiaffa, Dr. F. Lavini and Dr. M. Manca

GENERAL POINTS

The XCaliber Fixator is made of radiolucent material for unobstructed X-ray visualization. The metallic bolts, and the cam and bush of each ball-joint are the only radio-opaque components. Because it is radiolucent and made of a composite material, the ball-joint deforms after repeated tightening. It can be adjusted on the patient if repositioning of the fracture is required, but will not be strong enough for use on a second patient. Also the joint is sealed and cannot be dismantled for cleaning.

The XCaliber Fixator is strictly single patient use.

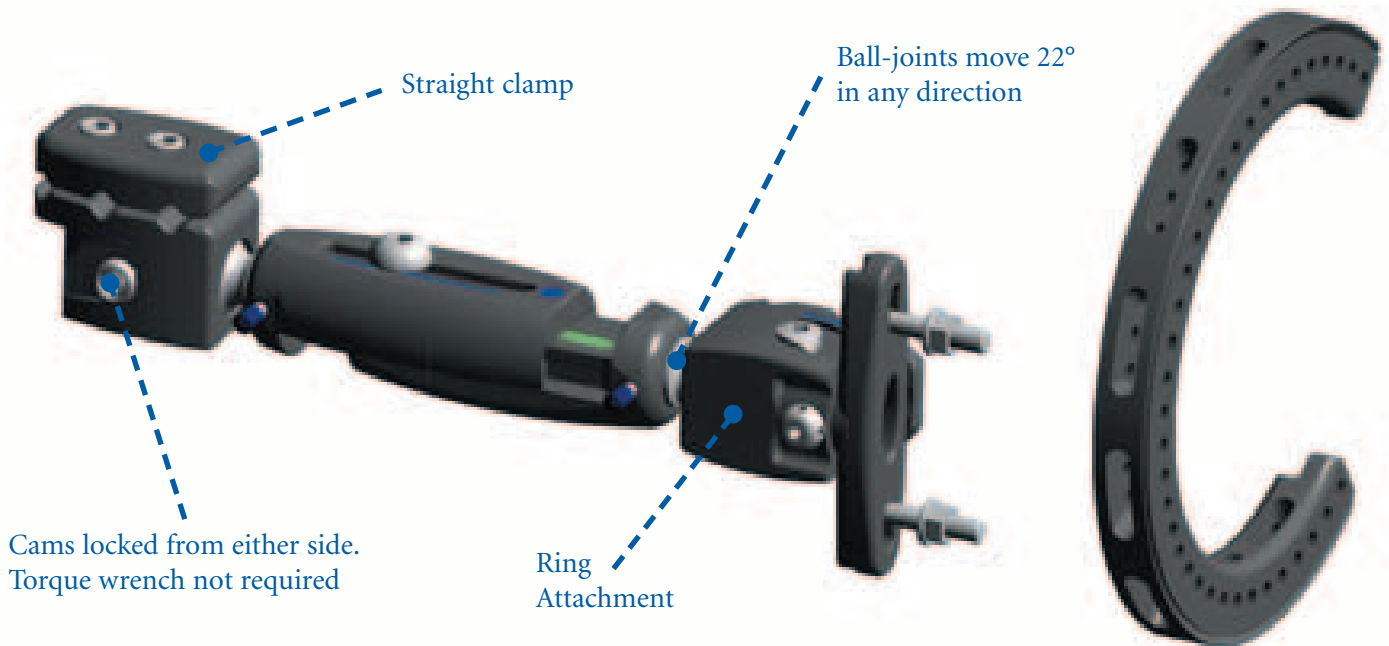

EQUIPMENT REQUIRED

99-91080	XCaliber Hybrid Kit, sterile
81043	Supplementary Screw Holder Bar Radiolucent, 300 mm
10038	Clamp for Supplementary Screw Holder Bar
80042 or 80044	Post, 50 mm Post, 100 mm
<i>Ring are available in the following diameters: 125 mm, 150 mm, 175 mm, 190 mm, 220 mm. They are available in aluminium or in a composite radiolucent material.</i>	
<i>Standard Instrumentation for Wire and Screw Insertion</i>	

STERILE R

CAUTION: Federal (U.S.A.) law restricts this device to sale by or on the order of a physician. Contents sterile unless package opened or damaged; Do not use if package is opened or damaged.

SAFE CORRIDORS FOR KIRSCHNER WIRE INSERTION

PROXIMAL TIBIA

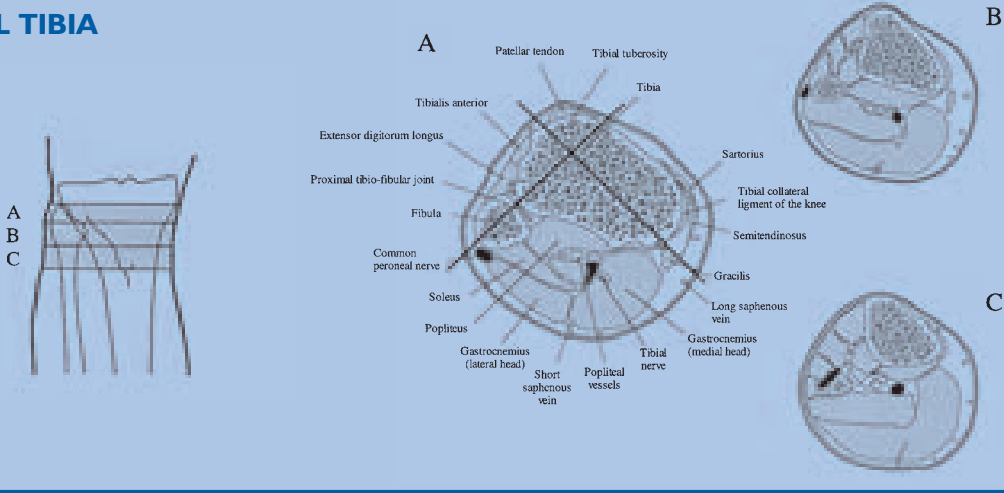

DISTAL TIBIA

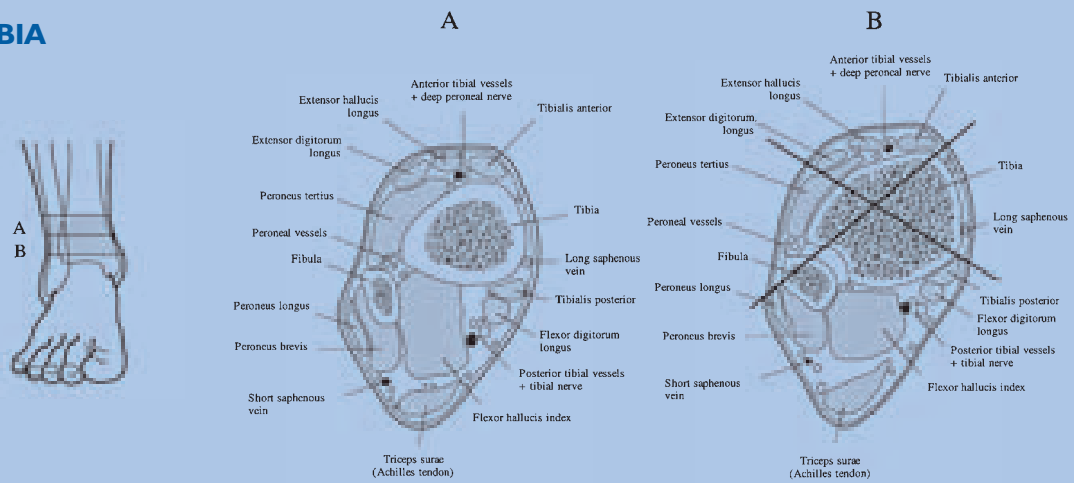

DISTAL FEMUR

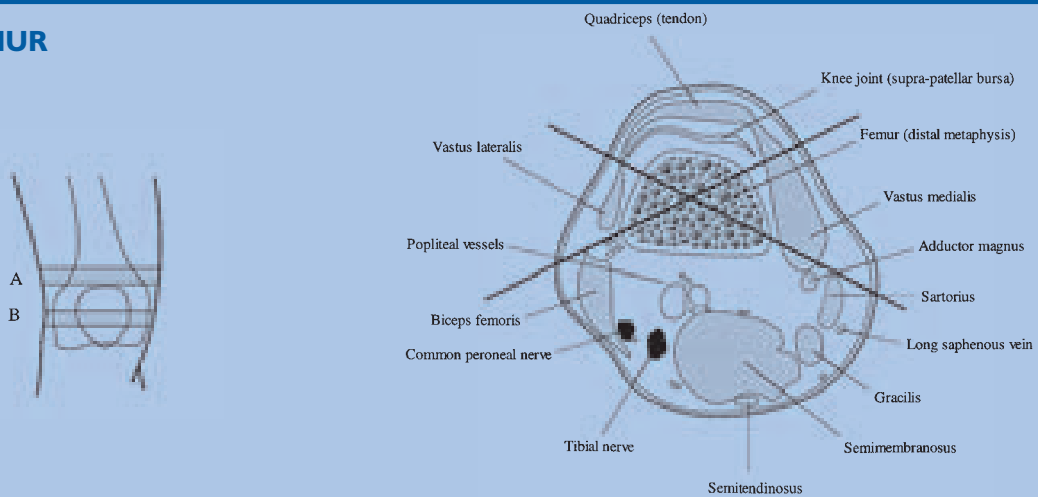

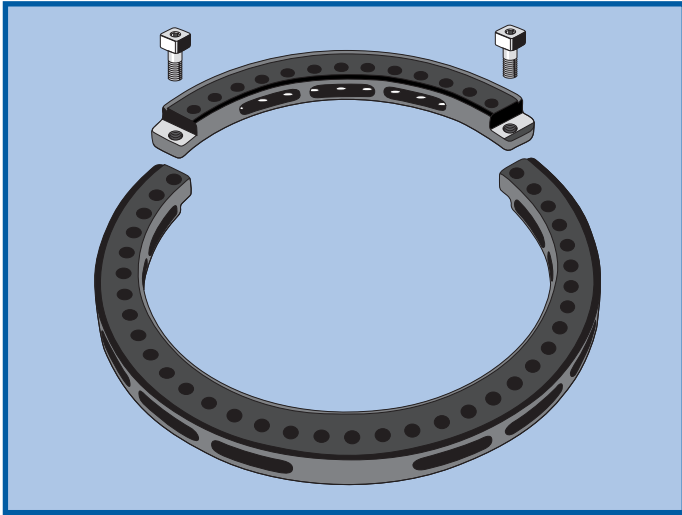

KIRSCHNER WIRE INSERTION

- Choose appropriate ring. Full circumference rings may be made by joining 1/3 and 2/3 rings together with locking screws.

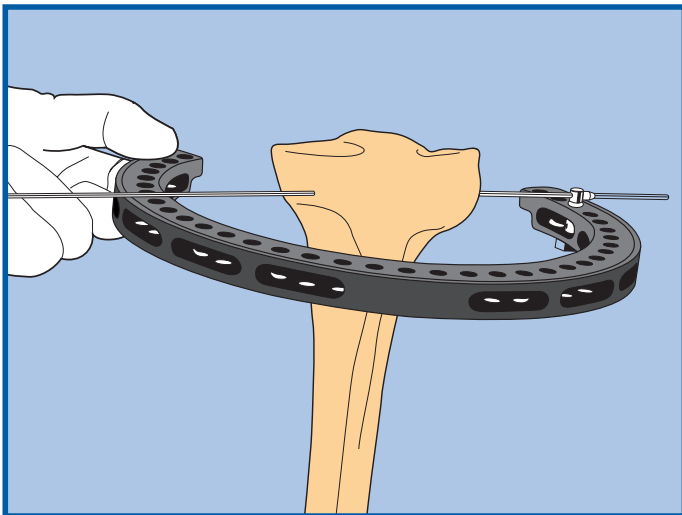

- Reference anatomically safe corridors on cross-section of limb. Insert wire closest to the joint first. Insert a two-hole securing pin into appropriate hole in ring. Introduce tip of K-wire with lateral olive through the two-hole securing pin. Push wire through soft tissues and drill through bone, while assistant maintains ring parallel to joint with limb centred within it. Avoid joint capsule. When wire has exited far cortex, stop drilling and ensure wire is parallel to ring and joint line. Continue to advance wire by tapping it with mallet, until lateral olive is against securing pin.

Note: Wire may be drilled above, below or through the ring, for best position relative to fracture and joint capsule.

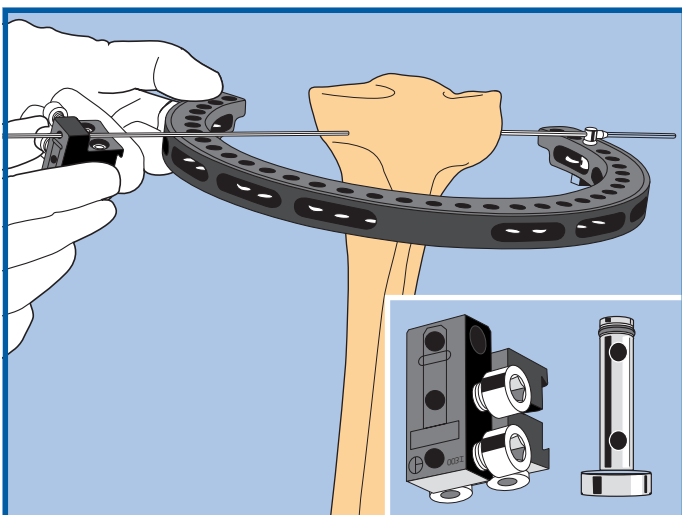

- Loosen all screws of three-hole wire clamp slider unit. Orient clamp in same direction as securing pin. Introduce wire into appropriate hole in slider unit.

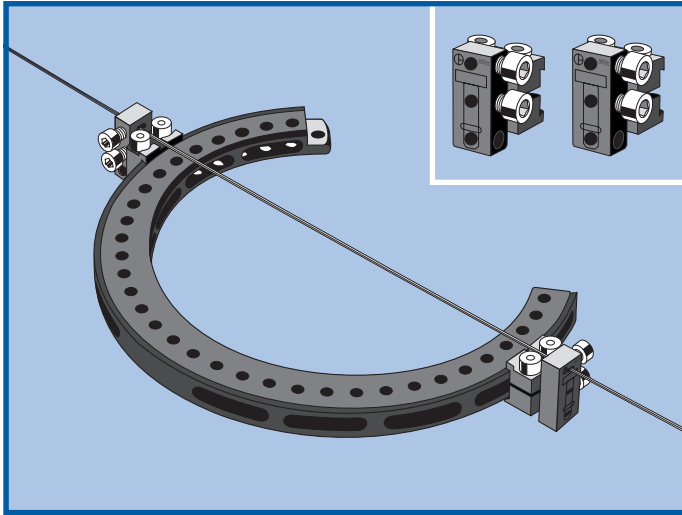

- If a K-wire without olive is used attach it to ring using a three-hole wire clamp slider unit at each end. Tighten both slider units to ring. Tighten wire clamp screw on one end of wire.

Note: The first wire may be inserted free-hand.

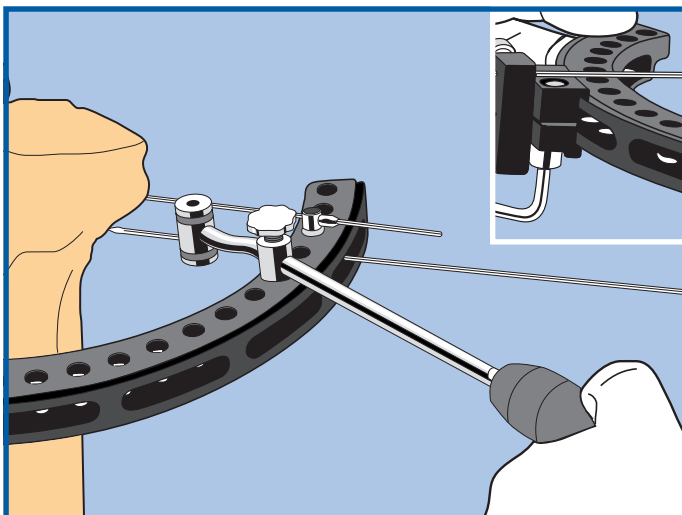

- Insert parallel wire next through second hole in securing pin, using wire guide. Disconnect the slider unit temporarily from the ring and then insert it over both wires. Tighten slider unit on to ring fully, using 3 mm Allen wrench. Position limb in centre of ring.

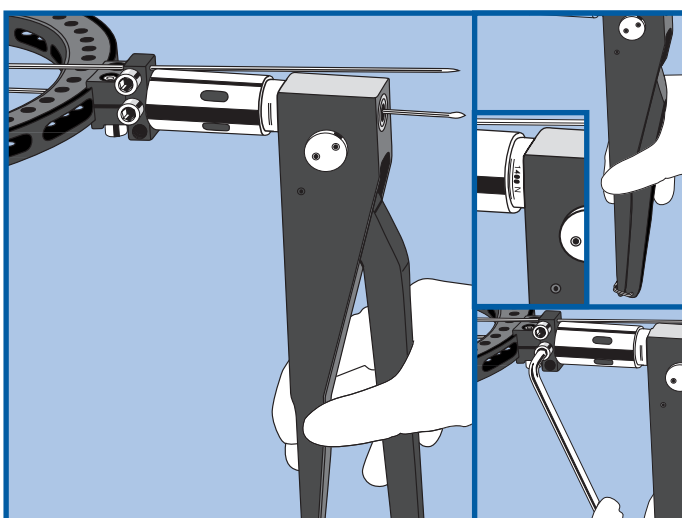

- To tension wires, open handle of wire tensioning device to fullest extent. Insert wire through the device and position it against face of slider unit. Tension wire to minimum of 1200 N, in two stages if necessary. Tighten wire clamp screws with 5 mm Allen wrench. Cut and/or bend wire and apply wire cover.

Note: Where K-wires without olive have been used in conjunction with two three-hole wire clamp slider units, tighten wire clamp screws at one end, and tension at the other as above.

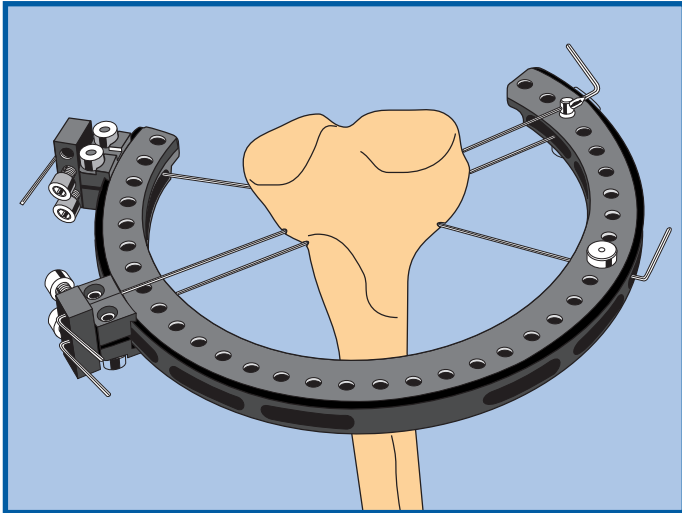

- Insert crossing wires at widest angle neurovascular structures will permit (usually between 50°-70°). For optimal ring stability wires should cross in the centre of the tibia. Insert the securing pin into the ring, upside-down relative to the first securing pin to prevent wires from intersecting in bone.

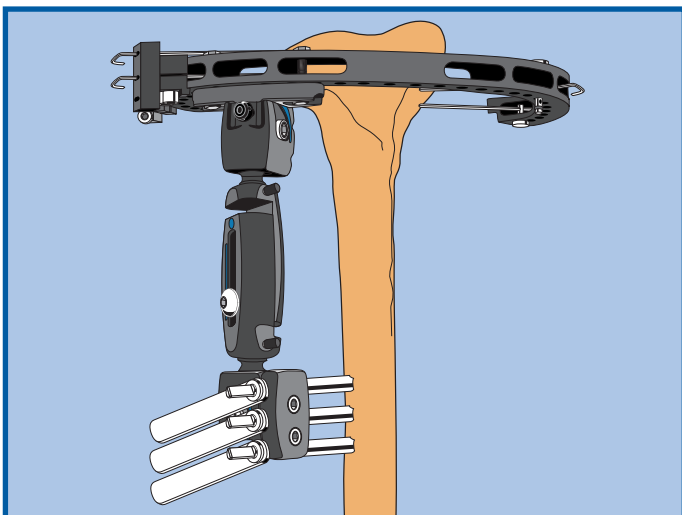

DIAPHYSEAL SCREW INSERTION

- Reduce fracture further by manipulation of ring and limb.
Attach fixator to ring using the nuts and washers. Tighten them with the Open End Wrench (81031). Position fixator parallel to long axis of bone with cams and all locking nuts accessible for tightening. Make sure fixator body is neither fully closed nor fully open. Clamp acts as its own template for screw insertion. Insert bone screws in standard manner (See Manual 1, “Basic Considerations”). Where two screws are inserted, use clamp seats 1 and 3. Generally in adults three screws are recommended.

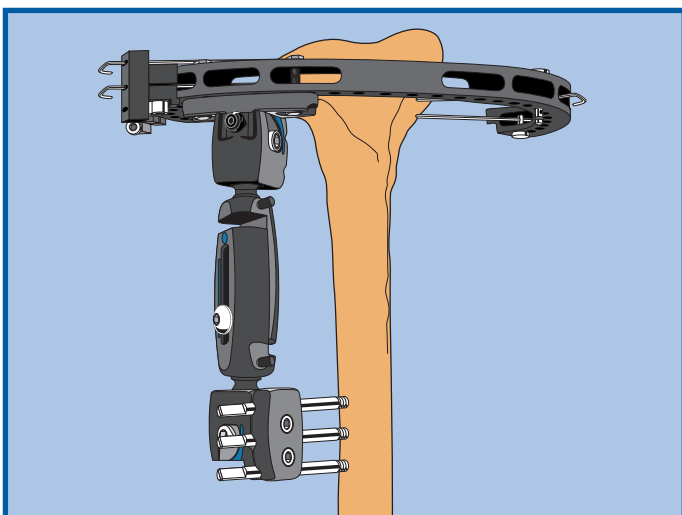

- Confirm fracture reduction. Accurate reduction is aided by the fact that the fixator is radiolucent, allowing unobstructed views on image intensification. Hold the reduction in a good position, while an assistant PARTIALLY tightens the cams and central body locking nut with the Allen wrench. Tighten the central body locking nut. Check reduction and lock the cams definitively with the Allen Wrench.

Note: Final locking of the ball-joints is achieved with the Allen wrench; a torque wrench is not required. The cams can be locked from either side of the clamp. They should be turned towards the thicker section of the coloured insert until tightly closed, and the cam is at least 50% of the way across the recess.

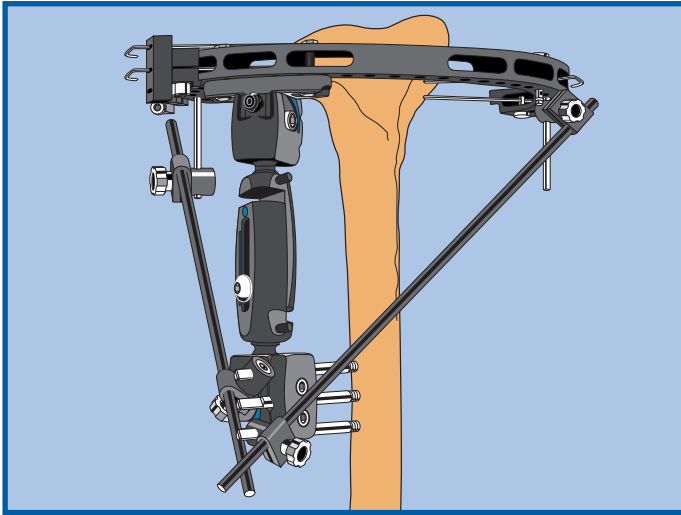

- Reinforcement bars may be added to increase stability, and are advised if the fracture is unstable. Insert post through ring and attach bar using a supplementary screw holder clamp. Attach opposite end of bar to bone screw using another supplementary screw holder clamp. As healing progresses, remove reinforcement bars to increase load sharing at the fracture site.

The Orthofix Quality System has been certified to be in compliance with the requirements of:

- Medical Devices Directive 93/42/EEC, Annex II - (Full Quality System)
 - International Standards EN 46001/ISO 9001
- for orthopaedic external fixator systems including bone screws, nails and wires, sterile external and internal fixation systems.

 See "Orthofix External Fixation System" instruction leaflet (PQ EXF) prior to use.

Orthofix Srl wishes to thank:

S. BERKI, MD

Department of General, Trauma and Hand Surgery
University and County Hospital
Szentes, Hungary

V. CAIAFFA, MD

Clinica Ortopedica e Traumatologica
Università degli Studi di Bari, Italy

F. LAVINI, MD

Clinica Ortopedica e Traumatologica
Università degli Studi di Verona, Italy

M. MANCA, MD

Clinica Ortopedica e Traumatologica
Ospedali di Massa e Carrara, Italy

for their invaluable help in the preparation of this Quick Reference Guide and their contribution to the design and refinement of the equipment described.

Your Distributor is:

www.orthofix.com



ORTHOFIX - Wonersh House - The Guildway - Old Portsmouth Road
Guildford - Surrey GU3 1LR - England
Tel. 44 1483 468800 Fax 44 1483 468829