

The XCaliber Meta-Diaphyseal Fixator

By Dr. S. Berki, Dr. V. Caiaffa, Dr. F. Lavini and Dr. M. Manca

GENERAL POINTS

The XCaliber Fixator is made of radiolucent material for unobstructed X-ray visualization. The metallic bolts, the cam and bush of each ball-joint, are the only radio-opaque components. Because it is radiolucent and made of a composite material, the ball-joint deforms after repeated tightening. It can be adjusted on the patient if repositioning of the fracture is required, but will not be strong enough for use on a second patient. In addition the joint is sealed and cannot be dismantled for cleaning.

The XCaliber Fixator is strictly single patient use.

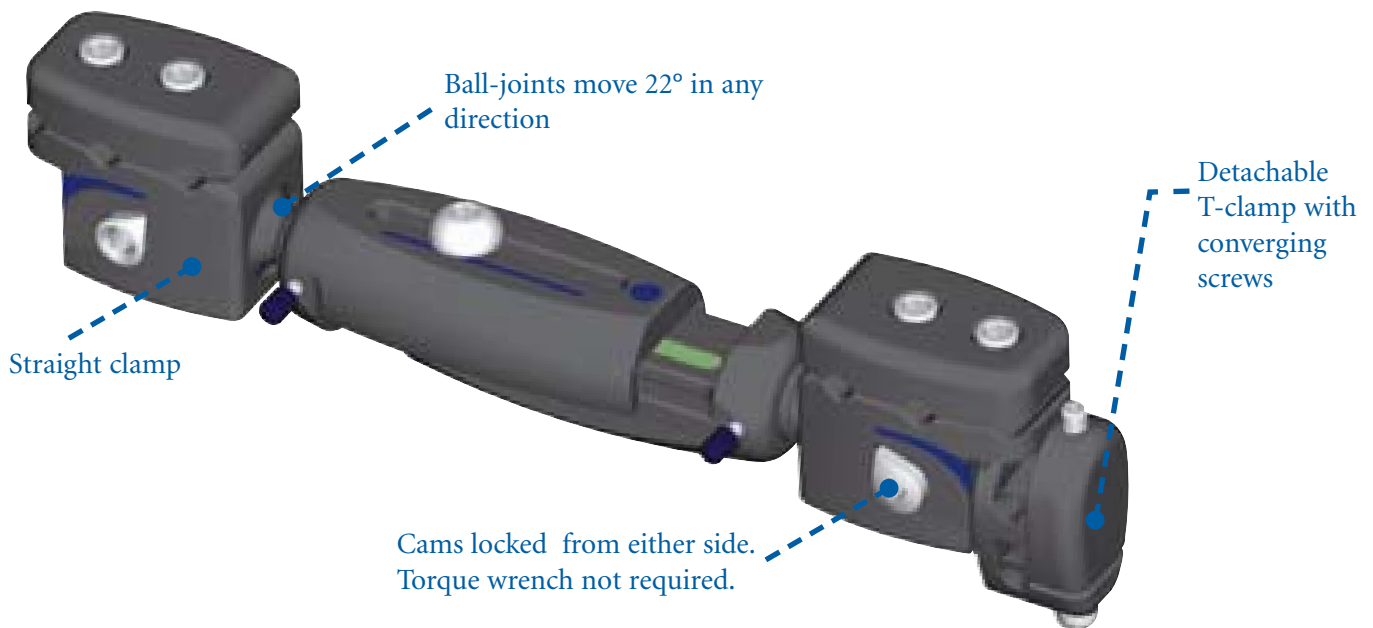

EQUIPMENT REQUIRED

99-91215	XCaliber Meta-Diaphyseal Kit with Dynamic Compression/Distracton Unit, sterile
99-91210	XCaliber Meta-Diaphyseal Kit with Static Compression/Distracton Unit, sterile
19200	XCaliber Manipulation Forceps
99-91038	Supplementary Screw Holder (Bar and Clamps), sterile
90037	Supplementary Screw Holder

Standard Instrumentation for Screw Insertion

STERILE R

CAUTION: Federal (U.S.A.) law restricts this device to sale by or on the order of a physician. Contents sterile unless package opened or damaged; Do not use if package is opened or damaged.

DIAPHYSEAL FRACTURES

TIBIA

- Reduce the fracture as anatomically as possible, emphasizing rotational correction. A fixed position on a fracture table with a Steinman pin is recommended.

Screw Insertion

- Insert screws into the shortest or most difficult segment first, from the anterior or antero-medial aspect of the tibia. Make a 15-20 mm incision so that the skin around each screw is not too tight. The underlying tissues also require broad dissection down to the bone.

- Insert a screw guide perpendicular to the longitudinal axis of the bone. Use a trocar to locate the midline by palpation. Keep the screw guide in contact with the cortex by gentle pressure, withdraw the trocar, and tap the screw guide lightly to anchor its distal end.

Note: If the placement of this screw is critical because it is close to a joint, the position can first be checked by inserting a 2 mm Kirschner wire. A screw guide can be centred over the wire by using a Ruland wire guide.

- Insert the correct drill guide into the screw guide. Use screw guides for every screw insertion to minimize soft tissue trauma. We recommend a 3.2 mm drill bit for cancellous bone, and a 4.8 mm drill bit for cortical bone.

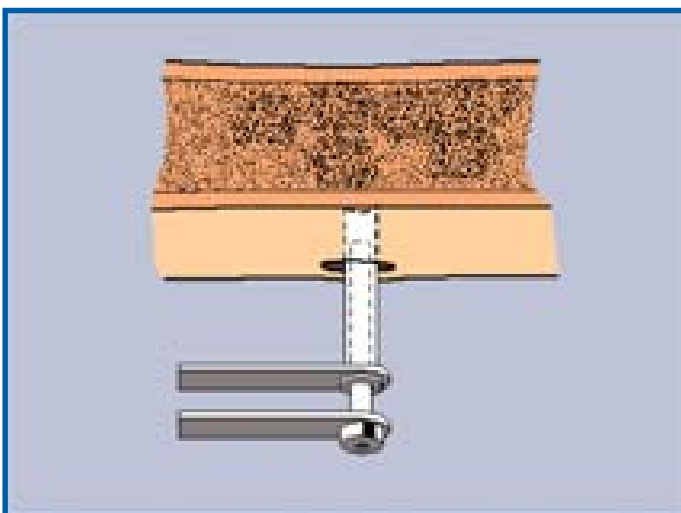
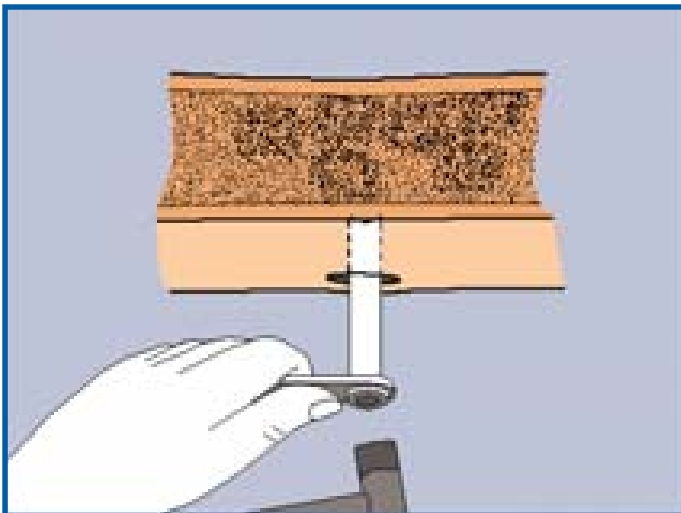
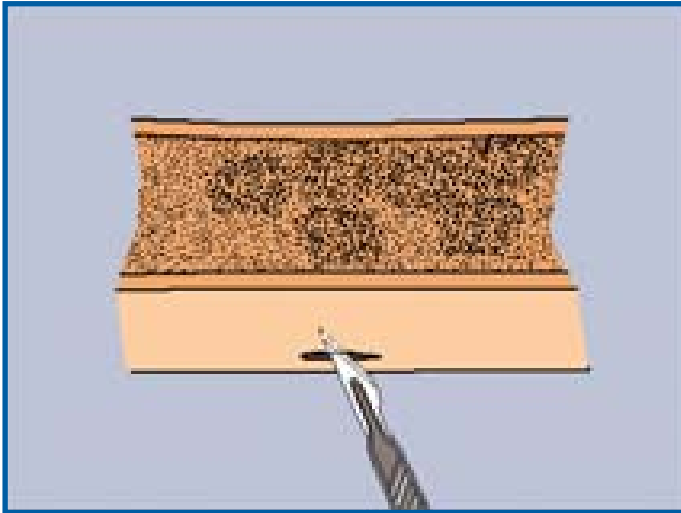

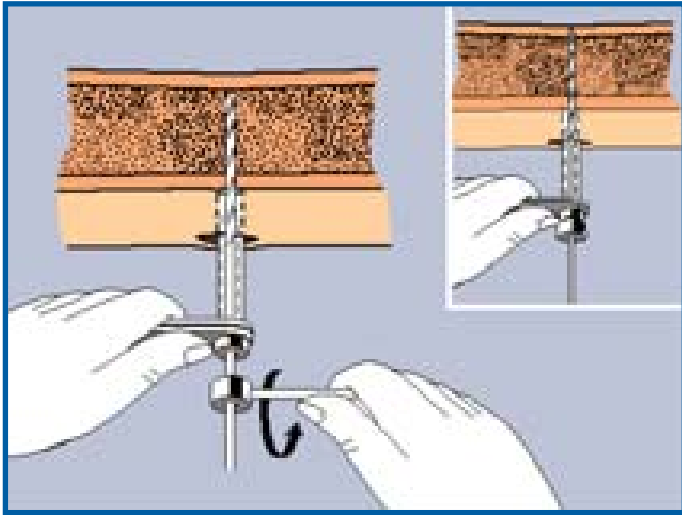

- Drill at 500-600 rpm through the first cortex with the correct drill bit and drill stop, checking that the drill bit is at right angles to the bone. The force applied to the drill should be firm and the drilling time as short as possible to avoid thermal damage. Stop at the second cortex, offset the stop collar by 5 mm, and continue through the bone. Ensure that the drill bit completely penetrates the second cortex. If a preliminary K-wire has been used, a cannulated drill bit can be used over the wire.

Note: Kirschner wires which are used for this purpose and cannulated drill bits should NEVER be reused.

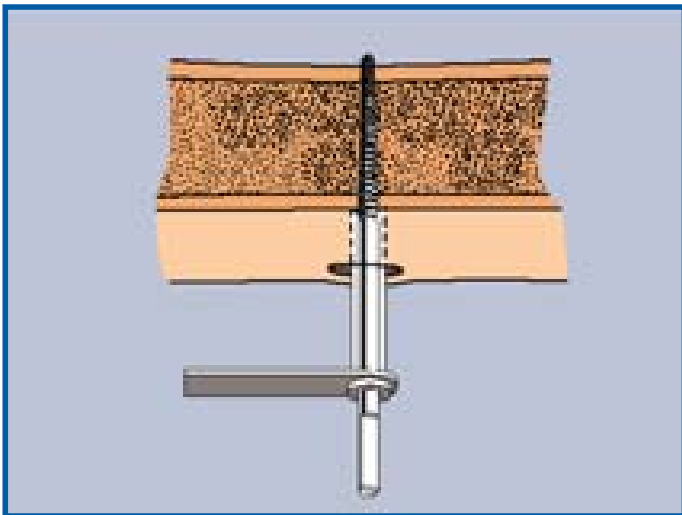

- Remove the drill bit and drill guide, keeping pressure on the handle of the screw guide. Insert the selected screw and turn it with the T-wrench until it reaches the second cortex. A further 5 or 6 half turns are then normally required to ensure that about 2 mm of the screw protrudes beyond the second cortex.

Warning! As the thread is tapered, repositioning the screw by turning counterclockwise will loosen the bone-screw interface. If the self-drilling XCaliber Bone Screws are being used, please refer to the Insertion Technique PG 20.

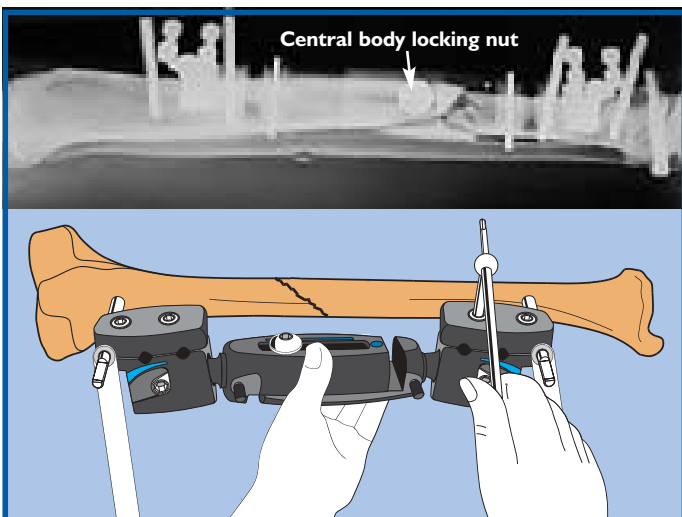

Fixator Application

- If desired, the T-clamp may be removed for this application. Leave the screw guide in position and apply the XCaliber Fixator with the central body locking nut and cams loosened. Before screw insertion into the second bone fragment, adjust the fixator body to the correct length, making sure that it is neither completely closed nor fully open. This will allow for final reduction. Check that the central body locking nut faces away from the bone so that it can be tightened, and that it does not obstruct views of the fracture site. The fixator body should be parallel to the bone axis. Insert a screw guide into the second clamp, as far as possible from the first for maximal stability; make the incision, and insert it down to the bone as before. Tighten the clamp locking screws with the Allen wrench to ensure that the clamps grip the screw guides. Repeat the screw insertion procedure as before.

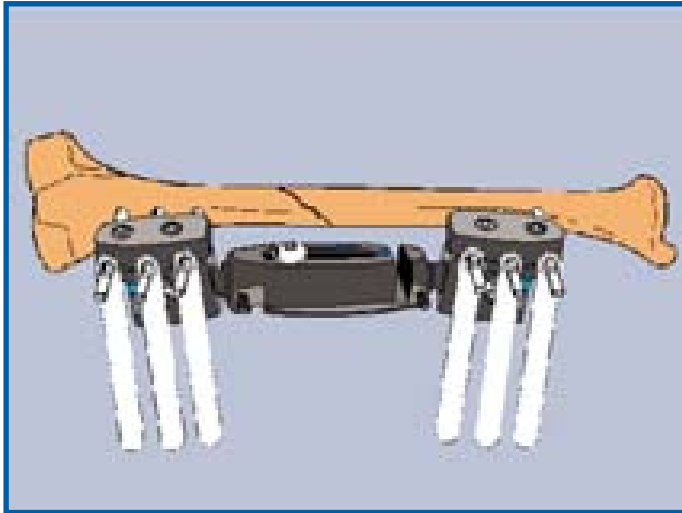

- Place the remaining screw guides in the clamps down to the bone; tighten the clamp locking screws to ensure that the screw guides are parallel, and insert the bone screws as before. The number of screws in each clamp is determined by the stability of the fracture, the weight of the patient, the bone-fixator distance and the quality of the bone. In adults we generally recommend that three screws are used each side of the fracture.

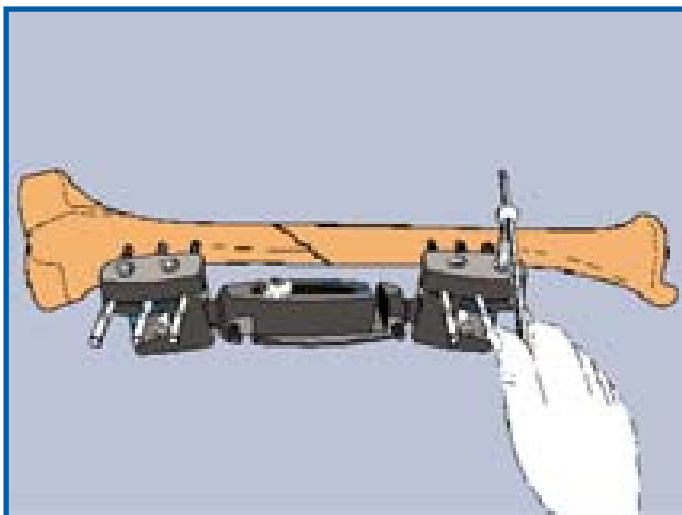

- Partially loosen the clamp locking screws and remove the screw guides. Position the XCaliber Fixator at least 2 cm from the skin to allow for post-operative swelling and cleaning. Align the body parallel to the major axis of the segment being treated. Fully tighten the clamp locking screws.

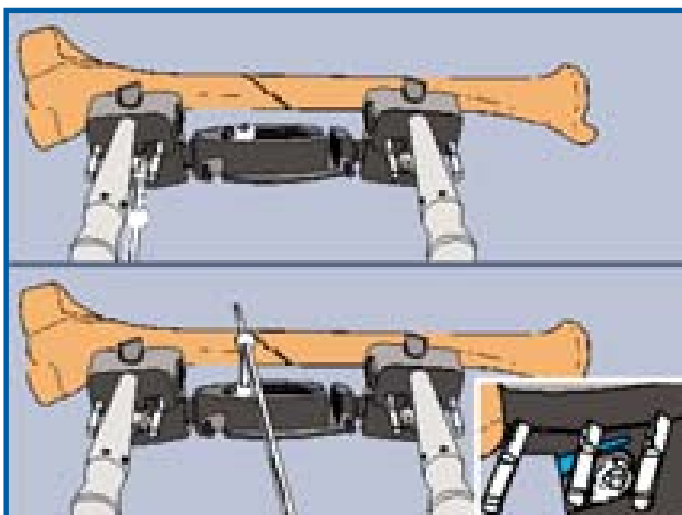

- Obtain final reduction with manipulation forceps. Place hooks of forceps over bone screws. Tighten the nut to lock the forceps in place. Insert Allen wrench through hole in handle if greater torque is required. Accurate reduction is aided by the fact that the fixator is radiolucent, allowing unobstructed views on image intensification. Hold the reduction in a good position, while an assistant PARTIALLY tightens the cams with the Allen wrench. Tighten the central body locking nut. Check reduction and lock the cams definitively.

Note: Final locking of the ball-joints is achieved with the Allen wrench; a torque wrench is not required. The cams can be locked from either side of the clamp. They should be turned towards the thicker section of the coloured insert until tightly closed, and the cam is at least 50% of the way across the recess.

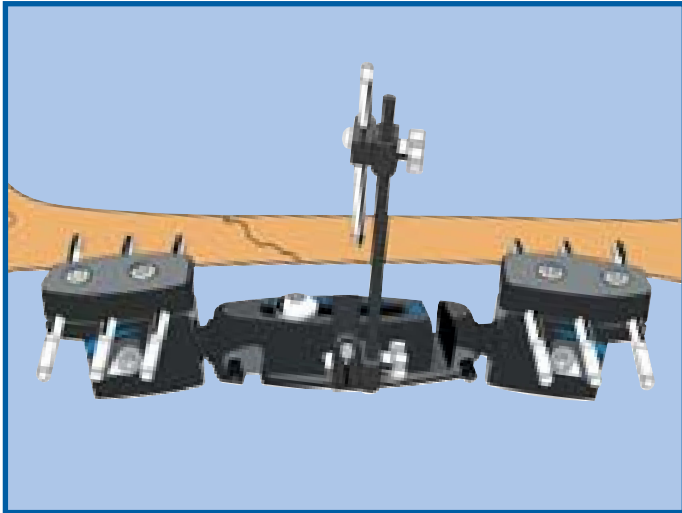

SUPPLEMENTARY SCREWS

- A fracture will be held in a more stable position if the nearest bone screws are applied fairly close to the fracture margin, and if these distances are equal on both sides of the fracture. A minimum of 2 cm is recommended between the fracture and the nearest screw. A supplementary screw holder is supplied to achieve this. A screw should be inserted into the longer bone segment at an equal distance from the fracture as the nearest screw in the short segment, using a screw guide. This screw is attached to the fixator either with a clamp over the fixator body, or over the nearest convenient bone screw. A 6 mm Allen wrench should be used to tighten the supplementary screw holder clamps. A supplementary screw can also be used to stabilize a third fragment. This screw should be removed before the fixator is dynamized.

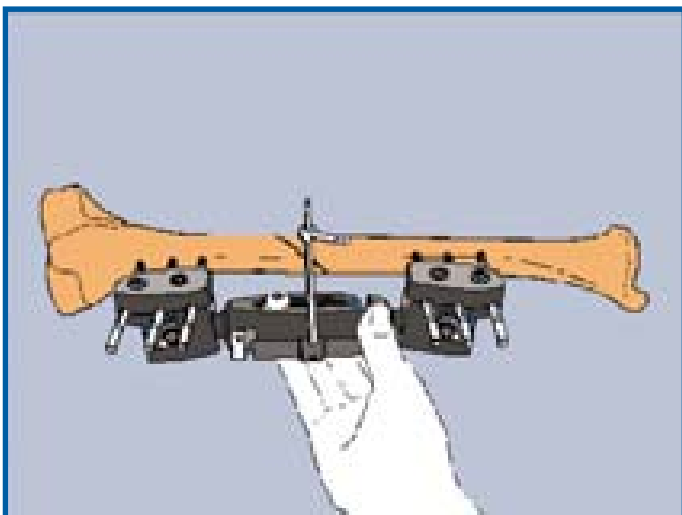

COMPRESSION-DISTRACTION UNIT

- To achieve compression or distraction, remove the plastic covers from the pins on the fixator body, attach the compression-distraction (C-D) unit and lock it in position with the Allen wrench. With the central body locking nut loosened, use the Allen wrench to turn the central element of the compression-distraction unit either clockwise or counterclockwise, (one full turn clockwise = 1 mm compression; one full turn counterclockwise = 1 mm distraction). Compression is never recommended in a fresh fracture. Release any skin tension around the screws by extending the skin incision.

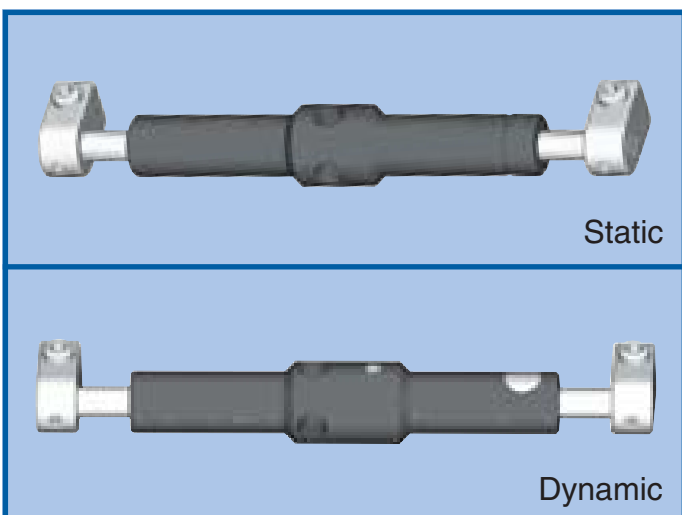

- There are two types of C-D unit: a static one for simple compression-distraction and a dynamic one which also allows early cyclic micromovement at the fracture site on weightbearing. The static C-D unit is for intra-operative use to alter the length of the fixator body. It should always be removed at the end of the procedure after the body locking nut has been tightened. It should not be left on the fixator post-operatively. The dynamic C-D unit is designed to allow early dynamization of the fracture, by cyclic micromovement on weightbearing, up to 2 mm at the fracture site. Attach the unit to the fixator pins and lock it firmly in position. Loosen the body locking nut.

Note: For full dynamization, remove the C-D unit and leave the body locking nut undone. This is normally recommended at 4 weeks, but should be delayed in cases of bone deficit or unstable fractures. Healing time is shortened and non-union rate decreased if full dynamization is carried out at the correct time.

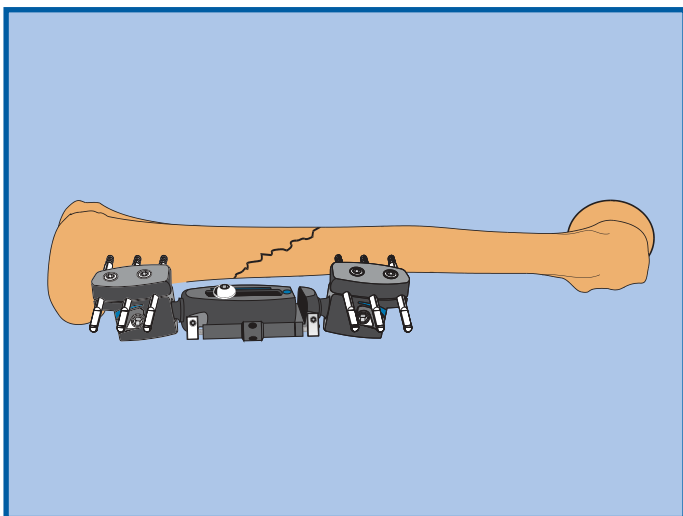

FEMUR

- Reduce the fracture, with particular attention to correction of rotational displacement. Apply the fixator to the lateral aspect of the femur. Insert 6 screws, 3 in each clamp, beginning with the shortest segment. Position the second group of screws so that the body of the fixator is open at least 1 cm. Screws should never be less than 2 cm from the fracture line. Use a supplementary screw if indicated as for the tibia. Obtain final reduction and lock the fixator as above.

Note: When unusually high loading conditions are likely, such as weightbearing with a femoral application or when the patient is very heavy, before the ball-joints are locked the fixator body should be aligned so that the body locking nut is at 90 degrees to the plane of the bone screws. In addition for increased stability the compression-distraction unit may be applied to the fixator body and locked into place.

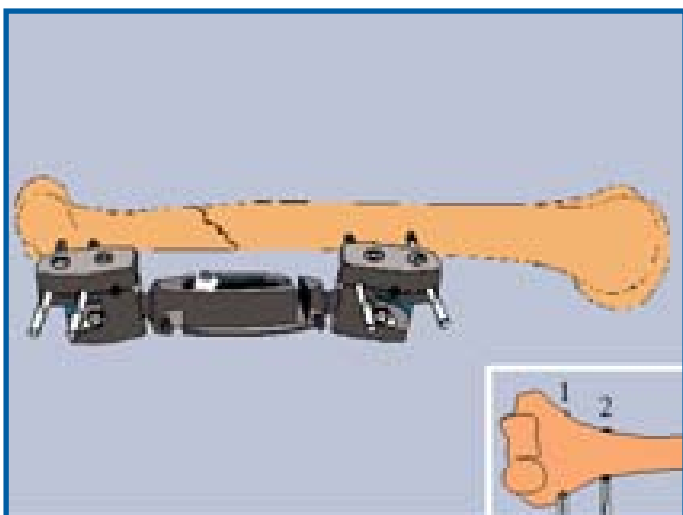

HUMERUS

- Reduce the fracture, with particular attention to correction of rotational displacement. Apply the fixator to the lateral aspect of the bone. Insert 4 screws, 2 in each clamp. Insert the most distal screw first, 1 cm proximal to the lateral epicondyle. The second distal screw should be inserted in the second seat of the clamp. To avoid risk of damage to the radial nerve, use an open procedure. Position the proximal screws to allow the body of the fixator to be open a minimum of 1 cm. Reduce and lock as above.



METAPHYSEAL FRACTURES

TIBIA: PROXIMAL METAPHYSEAL FRACTURES

Antero-Medial Application

- Insert the most anterior proximal screw first freehand, 2 cm distal to the knee joint. OsteoTite (HA-Coated) bone screws may be useful in this application. Position the screw within its screw guide in the proximal seat of the straight clamp. When using the T-clamp, the first screw should always be inserted in this screw seat.

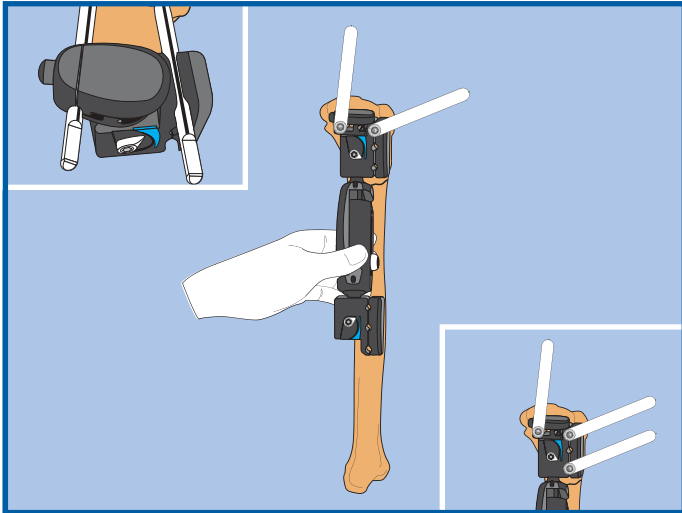

- The T-clamp allows for either parallel or convergent positioning of the proximal screws. The latter is achieved by rotating the T-clamp to find the most favourable position for the remaining screw(s). Rotation of the T-clamp is locked by tightening the plastic screw until the Allen wrench slips in the hexagon in the screw head. To loosen this screw, insert the end of a 3 mm Allen key into one of the holes in the edge of the screw head, and turn the screw counterclockwise. Insert the second screw.
A third screw may be used. Screws may be inserted in a straight or triangular configuration, depending on the shape of the proximal bone fragment. Three screws should always be used in adults, spaced as far apart as possible.

Note: When the convergent mode is used, make sure that the fixator is placed at the correct distance from the bone before inserting the second screw, as the fixator will not slide along convergent screws.

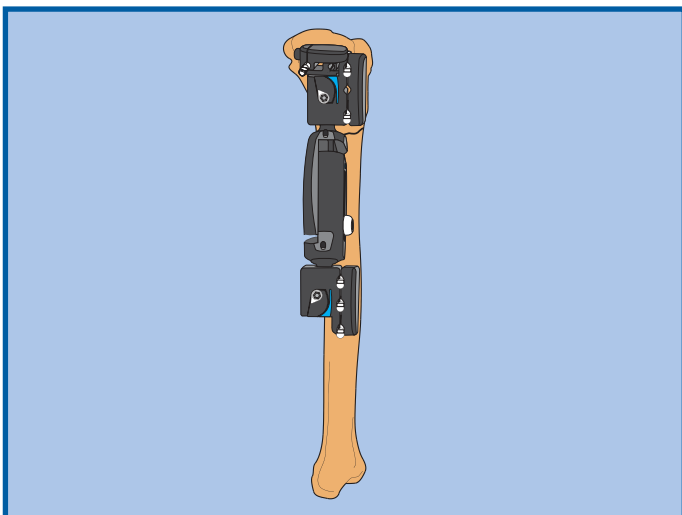

- Insert the diaphyseal screws, again checking that the fixator body is not completely closed. Lock the fixator as above.

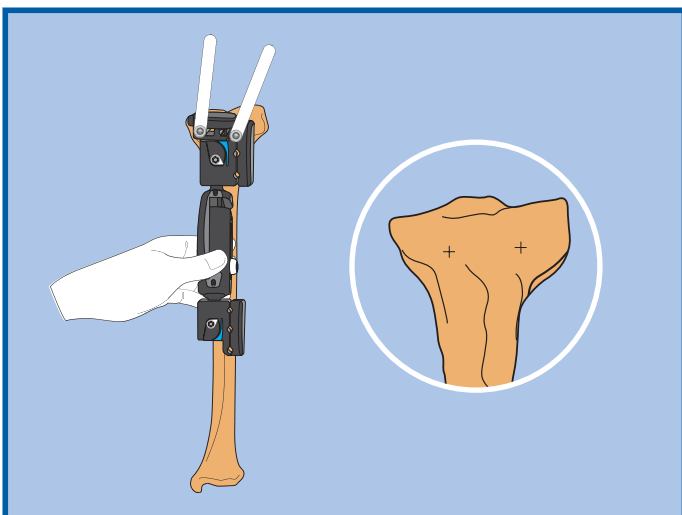

Anterior Application

- Insert the first screw in the proximal seat of the straight clamp and the second screw so that it converges slightly with the first, in the screw seat at the other end of the clamp.

Note: OsteoTite (HA-Coated) bone screws may be useful in this application.

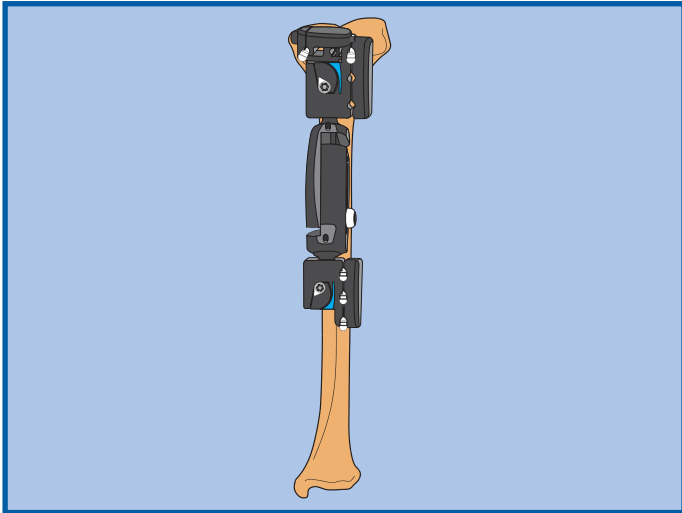

- Insert the diaphyseal screws, ensuring that the fixator body is not completely closed. Lock the fixator as above.

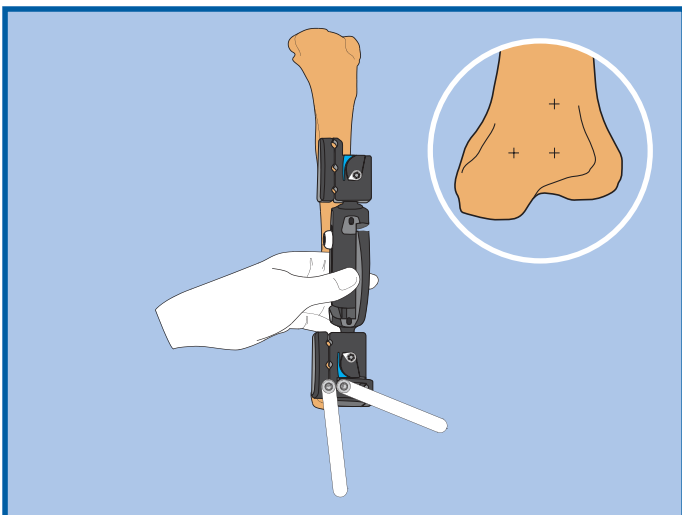

TIBIA: DISTAL METAPHYSEAL FRACTURES

- Insert the most posterior distal screw first, freehand, immediately anterior to the posterior border of the medial malleolus. Insert it with a screw guide into the most distal seat of the straight clamp. Insert the second distal screw in one of the seats of the T-clamp. A triangular screw configuration will be the most stable if there is room for the screws.

Note: OsteoTite (HA-Coated) bone screws may be useful in this application.

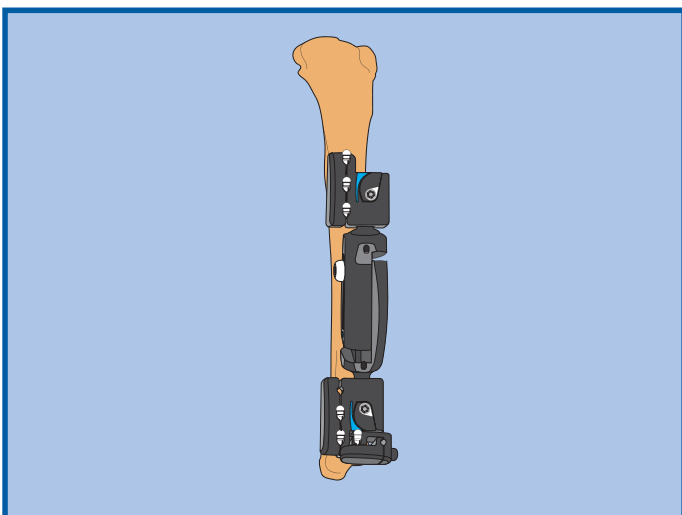

- Insert the diaphyseal screws, checking that the fixator body is not fully closed. Lock the fixator as above.

FEMUR: DISTAL METAPHYSEAL FRACTURES

- Apply the XCaliber Fixator laterally, inserting the most anterior distal screw first, about 1 cm behind the anterior edge of the lateral condyle. With this screw and its screw guide in the most distal seat of the straight clamp, insert the second distal screw in one of the seats of the T-clamp. Three screws should be used distally, in a triangular configuration if possible.

Note: OsteoTite (HA-Coated) bone screws may be useful in this application.

- Insert the diaphyseal screws, checking that the fixator body is open at least 1 cm. Lock the fixator as above.

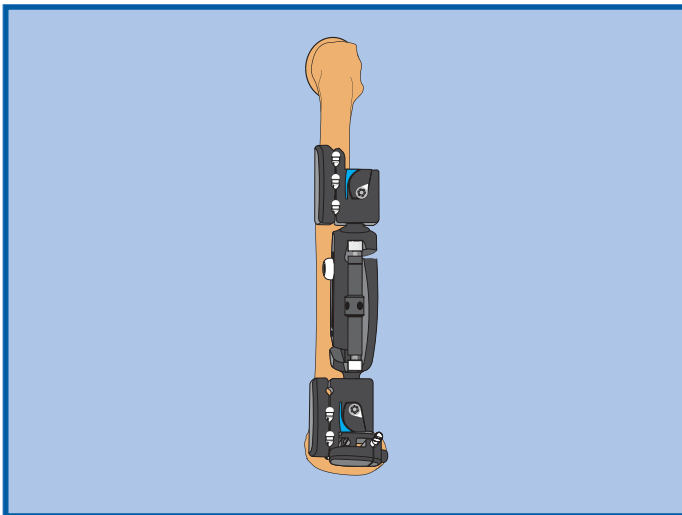
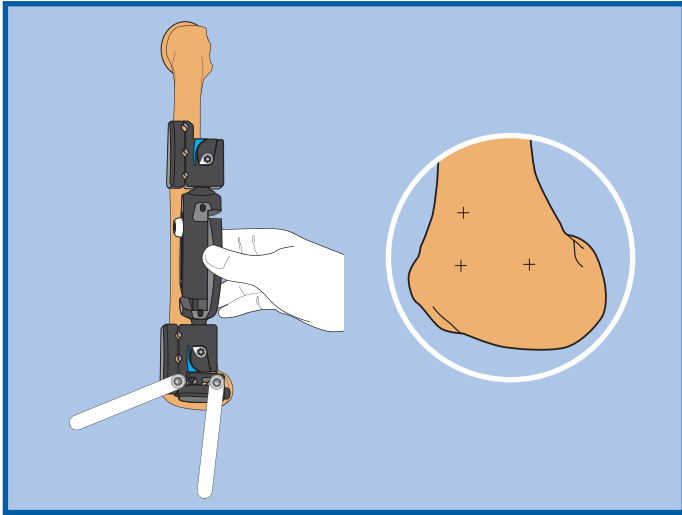

The Orthofix Quality System has been certified to be in compliance with the requirements of:

- Medical Devices Directive 93/42/EEC, Annex II - (Full Quality System)
- International Standards EN 46001/ISO 9001

for orthopaedic external fixator systems including bone screws, nails and wires, sterile external and internal fixation systems.

⚠ See “Orthofix External Fixation System” instruction leaflet (PQ EXF) prior to use.

Orthofix Srl wishes to thank:

S. BERKI, MD

Department of General, Trauma and Hand Surgery
University and County Hospital
Szentes, Hungary

V. CAIAFFA, MD

Clinica Ortopedica e Traumatologica
Università degli Studi di Bari, Italy

F. LAVINI, MD

Clinica Ortopedica e Traumatologica
Università degli Studi di Verona, Italy

M. MANCA, MD

Clinica Ortopedica e Traumatologica
Ospedali di Massa e Carrara, Italy

for their invaluable help in the preparation of this Quick Reference Guide and their contribution to the design and refinement of the equipment described.

Your Distributor is:

www.orthofix.com



ORTHOFIX - Wonersh House - The Guildway - Old Portsmouth Road
Guildford - Surrey GU3 1LR - England
Tel. 44 1483 468800 Fax 44 1483 468829